

# MYCADVANCE Air-Foil Aluminum Control Damper

**Series: 100**

**Model: FB (blades in Face and Bypass action)**

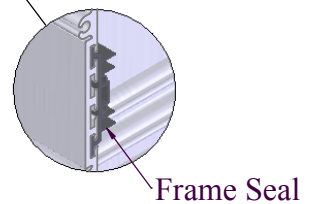
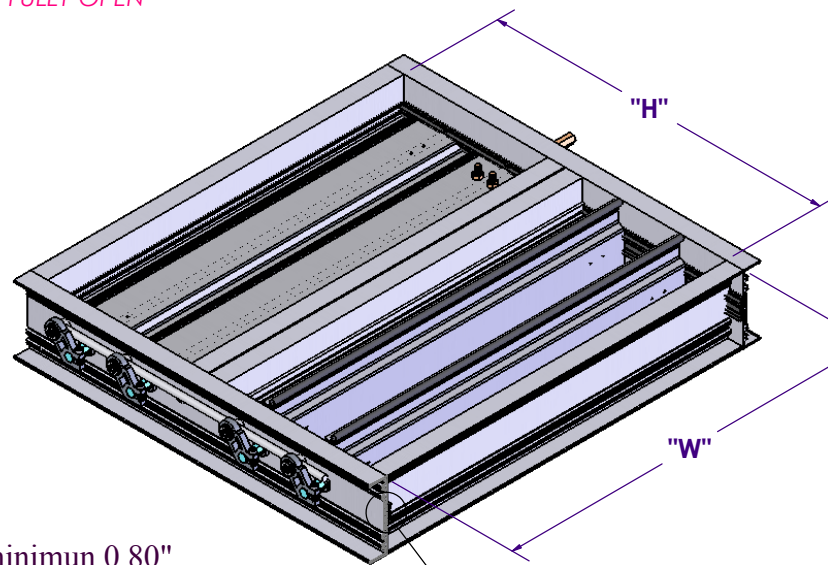
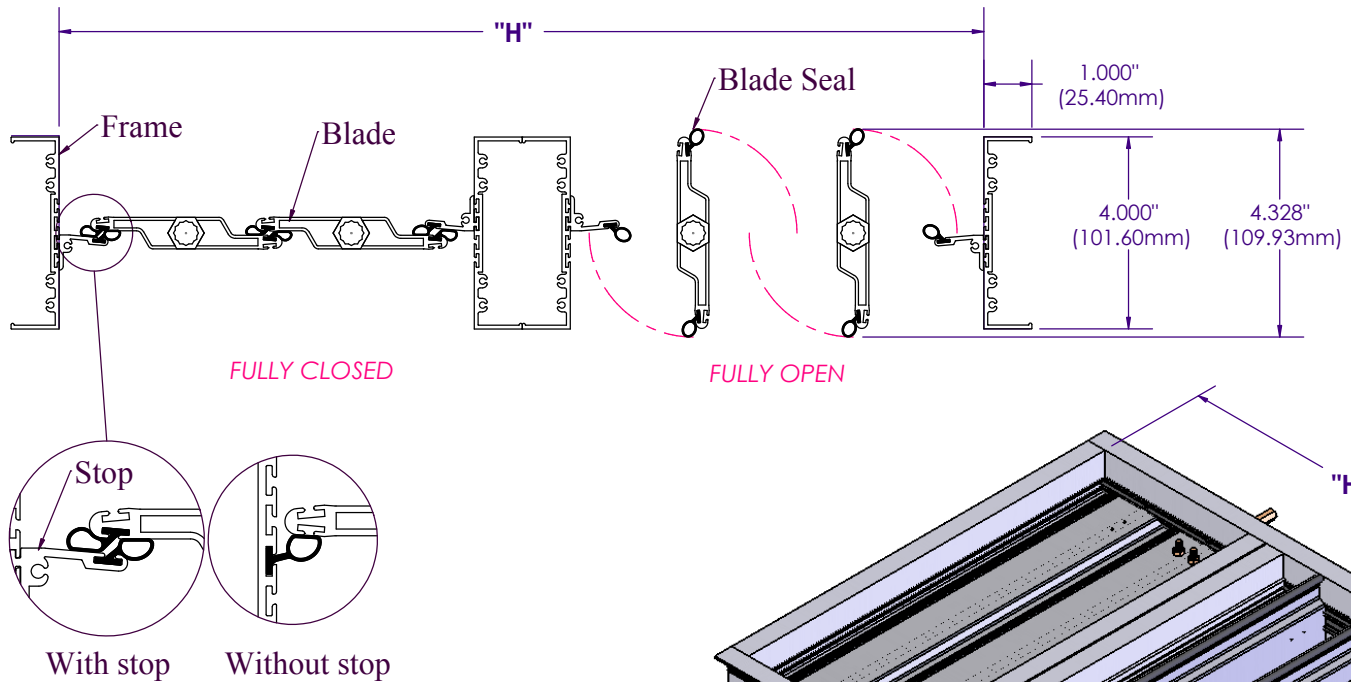

Drive Shaft

## STANDARD CONSTRUCTION:

- **Frame:** Aluminum extrusion 6063-T5 with a minimum 0.80" (2.03mm) in thickness, 4" deep and 1" mounting flange.
- **Blade:** Aluminum extrusion 6063-T5 in air-foil profile with a minimum 0.063" (1.60mm) in thickness and 4" wide.
- **Seals:** Blade seal is TPV rubber with a bulb profile. Frame seal is silicone rubber with dual bulbs and four walls profile.
- **Bearings:** Moulded Acetal (POM) copolymer that has high tensile strength, fatigue resistance, excellent lubricity and moisture absorption.
- **Blade Stop:** Aluminum extrusion 6063-T5. Most dampers have stops installed at two end frames except for some dimension limitation or customer's request.
- **Axles:** Hexagonal aluminum rod, 7/16" (11.11mm) flat to flat.
- **Drive shaft:** Hexagonal steel rod, 7/16" (11.11mm) flat to flat and 12" in length.
- **Linkage hardware:** Concealed in frame and constructed of aluminum and steel.
- **Finish:** All aluminum parts have mill finish. All steel parts are zinc plated.
- **Operation Temperature:** From -40°F (-40°C) to 180°F (80°C).
- **Air Leakage:** extremely low.
- **Damper Sizes:** Minimum 4 1/4"W x 4 1/4"H (108mm x 108mm), Maximum 60"W x 60"H (1524mm x 1524mm).